

FLYWHEEL KEYWAY CUTTER

MACTECH PORTABLE MACHINING SOLUTIONS

Portable Flywheel Keyway Cutting and Repair

The Mactech Flywheel Keyway Cutter is a portable machine for refurbishing and repair of flywheel keyways. The Keyway Cutter provides precision cuts on keyway length, width and depth. The machine features variable speed motor-driven keyway length feed with manual override and manual feed for keyway width and depth.

Specifications:

- Max Keyway Length: 15.30 inches (389mm)
- Max Keyway Width: 1.37 inches (35mm)
- Max Keyway Depth: 3.00 inches (76mm)
- Drive Motor: 2:1 gear reduction air motor:
 - Max Output: 3.9 hp (2.91kW)
 - Speed at Max Output: 1325 rpm
 - Torque at Max Output: 15.5 ft-lbs (21Nm)
 - Minimum Starting Torque: 22 ft-lbs (30Nm)
 - Free Speed: 2660 rpm
 - Spindle Speed: 400-660 rpm
- Weight: 276 lbs (125kg)
- R8 Collet accepts standard end mill tooling.

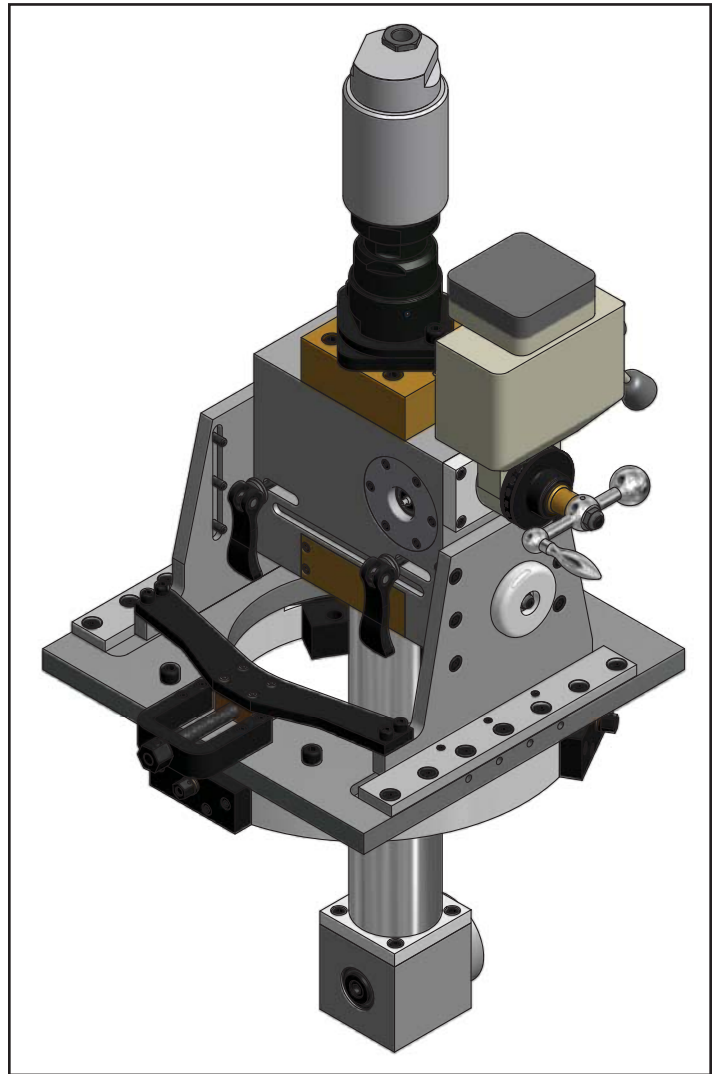

Flywheel Keyway Cutter

MACTECH
ON-SITE MACHINING SOLUTIONS

Mactech, Inc. • 4079 Pepin Ave. • Red Wing, MN 55066
PH: 651-388-7117 • TOLL FREE: 800-328-1488 • FAX: 651-388-0337 • www.mactechonsite.com

FLYWHEEL KEYWAY CUTTER

MACTECH PORTABLE MACHINING SOLUTIONS

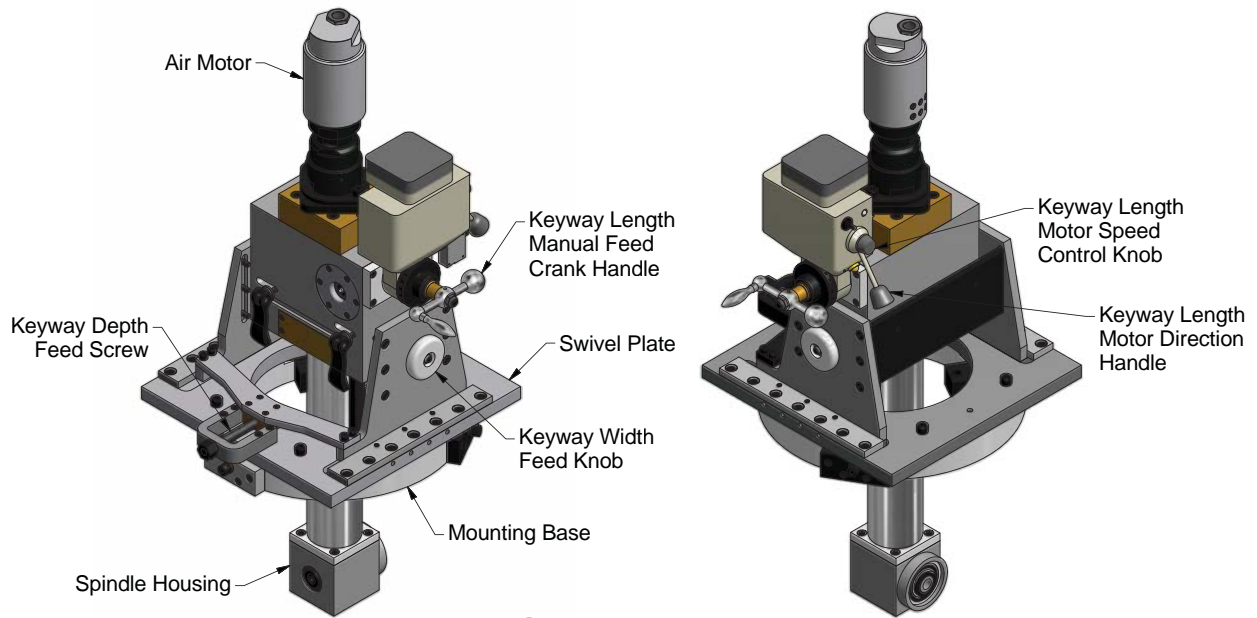

Components

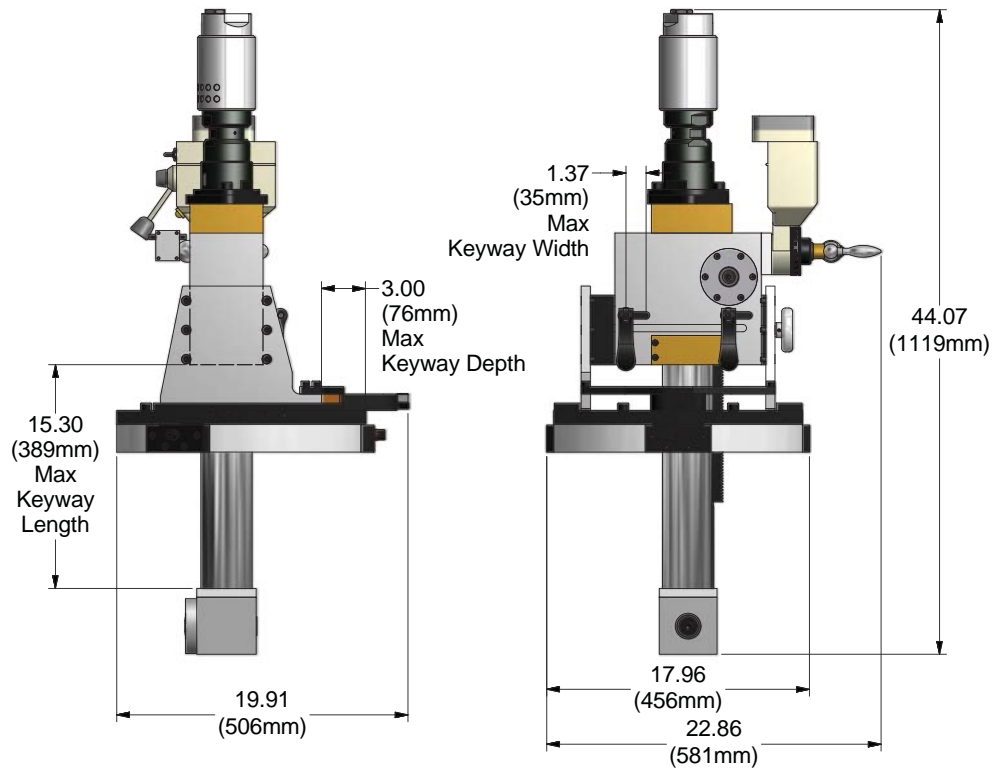

Dimensions

MACTECH

ON-SITE MACHINING SOLUTIONS